

# 8410/8411 V-LINE LAUNDRY

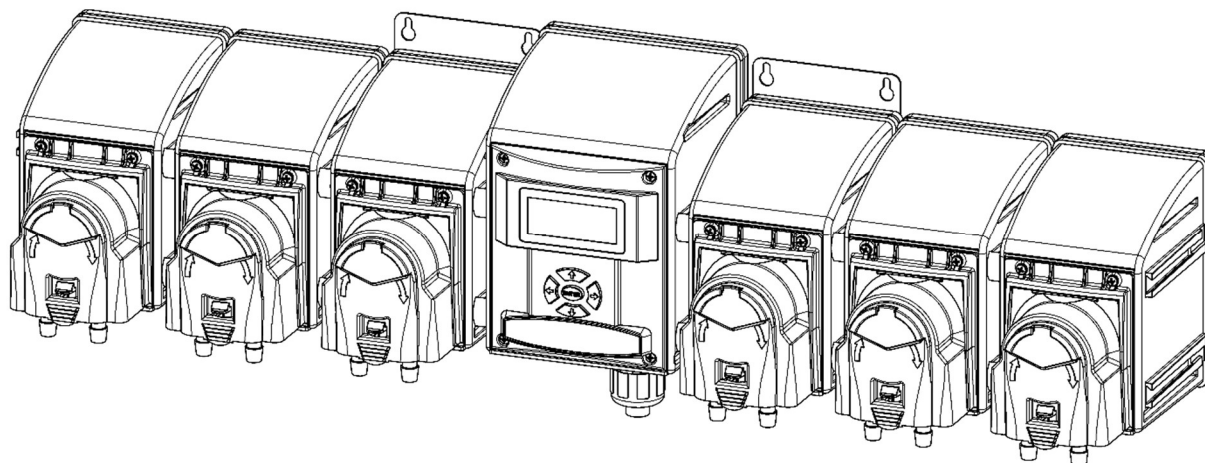

## Overview

The V-LINE dispenses from one to six laundry chemicals into any small capacity laundry machine. The operator may select between nine formulas. The dispenser may be triggered with a front panel button, remote button, or three automatic triggering options.

## Warnings

---



Installation of DEMA products must meet all applicable electrical codes and regulations established by national, city, county, parish, provincial or other agencies. It is possible that electrical codes and regulations require that a certified electrical contractor or engineer perform the electrical installation. For questions, contact a certified electrician.



**ALL ELECTRICAL POWER MUST BE TURNED OFF TO THE DISPENSER AND TO THE APPLIED MACHINE.**



All installations must conform to local plumbing codes and use approved backflow prevention devices. A pressure indicating tee is to be installed with existing faucets according to local plumbing codes in the state of Wisconsin and any other state that requires the use of a pressure indicating tee.



**ALWAYS WEAR PROTECTIVE CLOTHING AND EYEWEAR WHEN WORKING WITH CHEMICAL PRODUCTS.**

# Specifications

## Ordering Nomenclature

# 8410J-51-FR

### Remote

Add a "R"

### Flush Valve

Add a "F"

### Squeeze Tube Material

0 = EPDM

1 = Supertube

2 = Silicone

4 = Viton

### Number of Pumps

2 through 6

\*If flush valve is req'd, max number of pumps is 5.

Ex: 8410J-51-F. This will give you 5 pump module + 1 flush valve.

### Pump Size w/ Squeeze tube fitting

8410J = Small Blue QC Pump, JG 1/4 x 3/8, 105RPM

8410J60 = Small Blue QC Pump, JG 1/4 x 3/8, 60RPM

8410B = Small Blue QC Pump, Barb 3/8, 105RPM

8410C = C2 Pump, no fittings, 105RPM

8410T = Small Blue QC Pump, JG 1/4 x 1/4, 60RPM

8411J = Large Blue QC Pump, JG 3/8 x 3/8, 105RPM

8411B = Large Blue QC Pump, Barb 3/8, 105RPM

## Packing List

- V-Line Dispensing system (84xx) which contains pumps, power supply, electronic control board (IQ-50)
- Hook up kit which includes Velcro, zip ties, chemical label sheet. (V-Line Remote and cable are optional)
- Quick connect pump fittings

## Specifications:

- Main Power: 115V/230V 50/60Hz 2A
  - Units are shipped with a power cord that uses a U.S. 115VAC grounded plug
- Trigger Signal Connection: 10-250VAC 50/60Hz
  - System can be set to ignore signals less than 70VAC
- Pumps
  - 24VDC, 105RPM motors
  - Small Blue Pump Rate 16 ounces/min (460 ml/min) water
  - Large Blue Pump Rate 50 ounces/min (1480 ml/min) water

**8410 Series**  
**(larger pumps are not shown)**

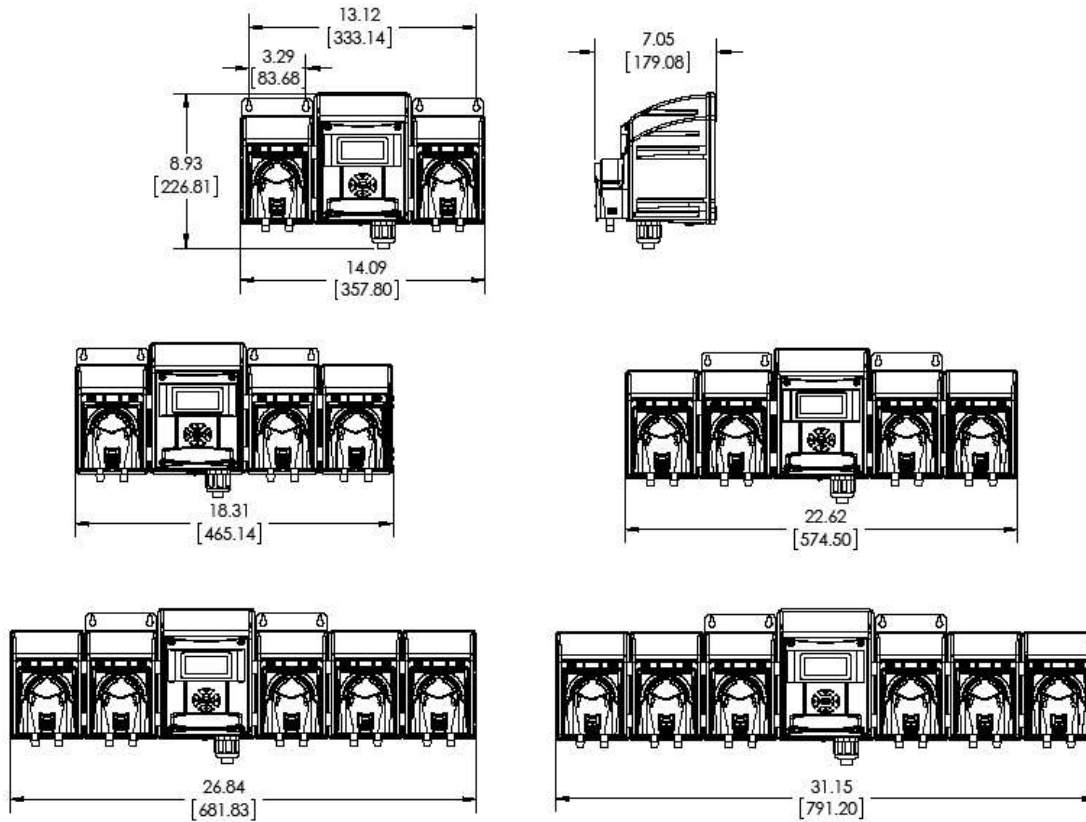

**FEATURES**

- Five Modes of operation
  - Formula Select Mode – Each pump receives a trigger from the machine supply valves and then performs the delay and dispensing as programmed. A trigger qualifying time may be programmed to ignore short valve cycles.
  - Push Button Mode – When the button on the front of the dispenser or the “start” button on the VLR (V-Line Remote, formula selector) is pressed, all pumps delay for a programmed time and then dispense the programmed amount of chemical.
  - Flex Trigger – This allows any pump to operated using any trigger. A pump can be programmed to operate with multiple triggers.
  - Sequence Mode – This allows the pumps to be triggered using the drain valve on the laundry machine. It is possible to us the hot and cold fill valves as well.
  - Relay Mode – This will cause the pumps to directly respond to trigger inputs.
- 9 Formula Capability
- Programming is performed on board at the control face of the system
- Load counter for each formula
- Total load count for all formulas
- Password protected programming
- Prewired for minimum installation time
- Quick-change squeeze tubes which require no tools
- Out of product alarms available

# Installation

---

## Electrical Installation – Main Power and Trigger Signal Wiring

All installations must be in accordance with city, county, parish, state or provincial electrical codes and should be performed by a certified electrician. A ½” nonmetallic conduit system must be used to install the power cord. For questions, please contact local licensed electrical contractor.

***Caution:*** Before electrical installation is started all electrical power must be turned off to the laundry machine at the appropriate service panel. Lockout and tag out procedures must be used. There is a potential for exposure to high voltage conditions when the V-Line enclosure is opened.

A complete survey of the laundry room or site installation should be completed in advance of starting the V-Line installation.

1. The V-Line is prewired with a power cord that includes a 115VAC grounded plug. Simply plug the power cord in grounded 115VAC wall outlet for main power.
  - a. Wall plug/socket adapters may be used to plug the power cord into various country plug configurations. The adapter must be rated to accept 115/230VAC 10A.
  - b. Alternative Main Power Hardwire– The molded plug can be cut off and connected directly to the laundry machine or alternate power source. The operating voltage 100-250VAC 50/60HZ. The system will automatically adjust to the incoming voltage. Laundry machine ratings and instructions must be observed. Consult with laundry machine or equipment manufacturer for connection information.
2. Select a location to mount the V-Line on a wall that will allow access to the chemical product containers and the chemical product feeds points on the laundry machine. Direct spray or high steam areas must be avoided.
3. If using the 951 series flush manifold or any other flush manifold , select a location that will allow all the electrical (power for solenoid valve and/or pressure switch) and tubing connections to be accessible. It should be noted that the flush output on the electronic control board is a 24VDC signal. The solenoid coil for the flush valve will need to match this output signal.

## Trigger Signal Wiring

It is possible to cutout supply signals from the machine that fall below 70VAC by using the voltage cutout switch.

When the V-Line enclosure is opened the voltage cutout switch can be accessed.

- When this switch is set to the 12V-100V setting the system can accept supply signals from the machine that range from 12-250VAC. ***This is the factory default setting for any product.***
- When this switch is set to 100V-240V, the system can accept signals that range from approximately 70-250VAC.

**Note:** When combining 2 or more trigger signal inputs from one supply signal from the laundry machine, it is recommended to have the voltage cutout switches set to 12V-100V settings. The system will accept 12-250VAC trigger signals.

**See the wiring configuration table on the next page for definition of the various wires.**

<b>V-Line Wiring Configuration (For Sequence Mode) (For Formula Select Mode or Relay Mode)</b>				
<b>Trigger Input</b>	<b>Line (signal)</b>	<b>Common</b>	<b>Function of Trigger Input</b>	
			<b>Sequence Mode</b>	<b>Formula Select/Relay Mode</b>
1	Black	White	Event Trigger	Signal Pump 1
2	Brown	White	Event Trigger	Signal Pump 2
3	Red	White	Reset (opt'l) ex. door switch	Signal Pump 3
4	Orange	White	Not Used	Signal Pump 4
5	Green	White		Signal Pump 5
6	Blue	White	Auto Formula Select (see AFS note)	

### **Sequence Mode Trigger Wiring**

There are two methods to wire for sequence mode

1. Use the normally open solenoid drain valve. Connect the “black” and “white” wires parallel to the solenoid drain valve. See laundry machine wiring diagram for appropriate connection points.
2. Use hot and cold fill solenoid valves. Connect the “black” to one valve, the “brown” to other valve, and the “white” to a common. See laundry machine wiring diagram for appropriate connection points.

### **Auto Formula Select**

- Auto Formula select allows the formulas to be selected based on a trigger signal that is received from the laundry machine. The following list outlines the setup of this feature:
  - The 6<sup>th</sup> trigger input (blue wire) on the V-Line is used for this purpose.
  - A trigger source that can be programmed at the laundry machine will be required. The timing of this trigger source is what determines which formula is selected by the V-Line control board (IQ-50).
  - To determine the amount of signal time for any formula simply calculate as follows: Multiply the formula number by 2 - Example: Formula 7 needs a trigger signal equal to 14 seconds. ( $7 \times 2 = 14$ ). A 14 second trigger signal to V-Line input number 6 (Blue and white wires) will change the V-Line to formula 7.

### **End User Remote**

The V-Line can be ordered with V-Line Formula Selection Remote. The remote is used for two reasons;

- To select wash formulas manually
  - To start a formula program when the system is setup in “push button” mode (see operation mode in programming section for more information).
1. Turn power off to the V-Line using the power switch on the bottom of the V-Line control module.
  2. Remove the (4) screws on face plate and loosen the face plate to access the control board.
  3. Remove the one of the white plugs on the bottom of the V-Line control module.
  4. Push the remote cable thru the hole and up to the control board and plug into the black RJ jack (similar to phone jack).
  5. Use the supplied strain relief piece that will surround the remote cable and plug into the hole at the bottom of the V-Line control module.
  6. Reassemble the face plate and reinstall the (4) face plate screws.

# Programming

---

## Programming Menu

1. To ENTER the programming menu, hold the right arrow for 4 seconds until the Language menu appears.
2. Press ENTER to select a different language. A cursor will appear next the displayed language.
3. Use the UP and DOWN to select a different language. English, French, Spanish and Portuguese are the 4 choices.
4. Press ENTER when the desired language is displayed.
5. Press the DOWN to access programming and the Enter Code screen will be displayed.
6. Press ENTER.
  - a. If it is a brand new unit or has never had an access code programmed the system will go immediately into programming.
  - b. If the system has been programmed previously with an access code, the system will display 4 zeros. The appropriate access code will need to be entered by using the LEFT and RIGTH and UP and DOWN. When the correct access code is displayed, press ENTER.

**Language  
English**

**Enter Code**

## Clear Load Counts

1. Use the UP and DOWN to scroll through the programming menu until you find Clear Load Counts.
2. Press the ENTER to access the menu.
3. Press ENTER to clear all load counts and then press the LEFT arrow to confirm the clearing of all load counts.
4. Press the LEFT to move back to the Programming Menu.

**Clear Loads  
Operation Mode  
Configuration  
Formula Lockout**

**Clear Load  
Counts**

**Left to Reset**

## Operation Mode

1. Using the UP and DOWN buttons scroll down through the programming menu until you find Operation Mode. Operation mode will dictate how the system will operate as well as allow certain programming menu's to unlock depending on which mode is selected.
2. Press the ENTER key to start the selection.
3. Use the UP and DOWN arrows to move cursor to desired operation mode.
4. Press ENTER to save the selection.
5. Press LEFT button to return to Programming Menu.

### Operation Mode Descriptions

- **Formula Select** – This mode causes each pump to run its delay and run time for the selected formula in response to the respective trigger input. Trigger 1 will run pump 1, trigger 2 will run pump 2, etc. The Trigger Time setting allows a qualifying time to be set to avoid false triggers because of stray signals. Trigger signals for this mode are typically found on supply valves on the laundry machine.
- **Push Button** – Selecting this mode causes all pumps to run when the ENTER key on the front of the V-Line or the START button on the VLR remote is pressed on one of the formula screens. All delays will start immediately with the key press and the pumps will run when the delays expire. Lockout will also be active. This prevents accidental re-triggering.
- **Flex Trigger** – Flex Trigger mode is similar to Formula Select mode, but each pump can be programmed to operate from any trigger. Any pump can be programmed to operate with multiple triggers as well.
- **Sequence** – Sequence mode allows automatic triggering of pumps when conventional supply signals are not available. Each pump delay and run time occurs in response to a sequential event from the laundry machine. The most typical way to use Sequence mode is to hook up the trigger signal number 1 input (black wire) and the common (white wire) to the drain valve, which is a normally open valve on most laundry machines. Each time the machine fills the drain valve is energized to the closed position. The trigger signal input number 1 will register the signal and count it as a fill. The system can be programmed to run pumps at any fill along with programming a final fill thus resetting the sequence count for a new wash cycle. As an alternative, the hot and cold fill valves can be used. In this case connect the trigger 1 to the hot valve and the trigger 2 wire to the cold valve. The common wire (white) may need to be split using a wire nut and a couple of short pieces of wire to complete the trigger circuit so that each valve will have the common wire connected.
- **Relay** – This mode causes the inputs to directly drive the outputs. No pump programming is required. If six pumps are used, pump six must be assigned to one of the first five trigger inputs. If a flush is used, the flush time may be programmed for each formula.

### Configuration

This function will define how many pumps will be used on the dispenser and set flush manifold operation settings.

1. Use the UP and DOWN to scroll through the Programming Menu until you find the menu Configuration.
2. Press the ENTER key to start the selection.
3. Use the UP and DOWN to select the pump configuration.
4. Press ENTER to save the selection.
5. To program flush, use the DOWN to move the asterisk (\*) to the flush.
6. Press the ENTER button and the cursor will appear next to the flush setting.
7. Use the UP and DOWN to adjust from “no” to a flush time in seconds.

**Clear Loads**  
**Operation Mode**  
**Configuration**  
**Formula Lockout**

**Operation Mode**  
**Formula Select**

**Press Enter**

**Operation Mode**  
**Push Button**

**Press Enter**

**Operation Mode**  
**Flex Trigger**

**Press Enter**

**Operation Mode**  
**Sequence**

**Press Enter**

**Operation Mode**  
**Relay**

**Press Enter**

**Clear Loads**  
**Operation Mode**  
**Configuration**  
**Units**

**Configuration**  
**Pumps – 5**

**Flush - No**

Note: This is the post flush time. The flush will automatically run with the pump if the flush time is set to 1 or more seconds.

8. Press the ENTER button to save the flush setting.
9. Press LEFT button to return to Programming Menu.

Notes:

- If 6 pumps are configured, the flush option is not available & the number 6 pump will need to be operated triggers 1-5, as there is no number 6 trigger input available.
- Flush time has a range of 1-999 seconds.
- When the six pump option is selected in Formula Select or Relay modes one of the first five triggers must be selected to operate pump six.

## Units

This feature allows pump programming in units of time or volume. The time is in seconds and the volume can be programmed in ounces or milliliters. When programming in ounces or milliliters it is necessary to calibrate each pump. See Calibration procedure below.

1. Use the UP and DOWN to scroll through the main menu to find Units. Press ENTER to change the units.
2. Press ENTER to change the units.
3. Use the UP and Down to scroll through the units, Seconds, Ounces or Milliliters.
4. Press ENTER when the desired unit is displayed.
5. Press the LEFT arrow button to move back to main menu.

## Calibration (only displayed when units are set to ounces or milliliters)

This feature allows each pump to be calibrated for accuracy allowing the system to dispense chemical based on units of volume, ounces or milliliters. A graduated cylinder or another measuring cup is required that can hold up to 8 ounces (240 ml) of liquid is required. Pumps must be primed with chemical. Personal safety equipment, latex gloves and safety glasses are need as well.

1. Use the UP and DOWN to scroll through the main menu to find Calibration. Press ENTER to calibrate pumps.
2. An asterisk will appear next to the Pump. Press ENTER and Use the UP and DOWN to select the desired pump to calibrate. Press ENTER to set the desired pump.
3. Use the DOWN to move the asterisk to Enter to Start.
  - a. Disconnect the outlet tubing from the pump to be calibrated.
  - b. Hold the empty graduated cylinder under the outlet of the pump.
  - c. Press ENTER to start the pump. Pump should start running. The display will begin showing a timer counting up in seconds.
  - d. When 6 to 8 ounces (180-250ml) is collected, press ENTER to stop pump.
  - e. Asterisk will automatically move to Amount = 0.00oz or ml
  - f. Use the UP and DOWN to set the amount of liquid that is in the graduated cylinder.
  - g. The Amount = xxx will change to Flow XX.X oz/m or ml/m
4. Press LEFT arrow button to return to main menu

**Note:** As an alternative, the Flow for each pump can be manually adjusted

1. Move the asterisk next to Flow XX.X oz/m
2. Press ENTER the asterisk will start flashing
3. Use the UP and DOWN to increase or reduce the flow rate.
4. Press ENTER when the desired flow rate is displayed.
5. Press LEFT arrow button to return to main menu.

Configuration  
Pumps – 5

Flush – 001s

Units  
Calibration  
Formula Lockout  
Program Formula

Units  
Ounces

Press Enter

Units  
Calibration  
Formula Lockout  
Program Formula

Calibration  
\*Pump 1  
Flow 16.0 oz/m  
Enter to Start

Calibration  
Pump 1  
Flow 16.0 oz/m  
\*Enter to Start

Calibration  
Pump 1  
\*Amount = 0.00 oz/m  
Enter to Start

Calibration  
Pump 1  
\*Flow 16.0 oz/m  
Enter to Start



## Formula Lockout

This feature allows the system to only operate pumps once from a given trigger signal input. Any subsequent trigger signals will be ignored during the active Formula Lockout clock. The Formula Lockout clock starts on the first trigger signal received to any of the 5 trigger signal inputs. At that point the active Formula Lockout clock will apply to all trigger signal inputs.

1. Use the UP and Down to scroll through the Programming Menu until you find the menu Formula Lockout and press ENTER.
2. Use the UP and DOWN to select the formula.
3. Press the ENTER to change the lockout time for the selected formula.
4. Use the UP and DOWN to set the lockout time for the length of the wash cycle for each formula. The time measurement is in minutes.
5. Press the ENTER key to save setting.
6. Press the LEFT arrow button to return to the Programming Menu.

## Program Formula (9 Formulas Max, will not display in Relay mode)

This will program pump run times for Level 1, Level 2, and Delay times for each pump.

1. Use the UP and DOWN to scroll through the Programming Menu and find Program Formula and press ENTER. An asterisk (\*) will appear as a cursor.
2. With the asterisk next to the "Form" number. Press ENTER to change the formula to be programmed.
3. When desired formula number is displayed, press ENTER to program pumps.
  - a. Use the LEFT and RIGHT to move from Level 1, Level 2 and Delay programming.
  - b. Use the UP and DOWN to select a pump or move back to the FORM selection.
  - c. Press the ENTER when at the desired pump to program a pump run time or delay.
  - d. Use the UP and DOWN to adjust the pump run or delay time.
    - i. The pump run range is 0-999s, 0-99.9ounces, or 0-9999ml.
      1. S = seconds, o = ounces and m = milliliters
    - ii. Delay Time in seconds for Formula Select & Sequence Modes, and in minutes for Push Button Mode.
  - e. Press ENTER to save the setting.
  - f. Repeat step 3 process for all pump runs and delay times.
4. Repeat steps 2 & 3 to program additional formulas.
5. Press the LEFT to return Program Formula screen.

*Note: Only the number of pumps that were set in the configuration setup will be displayed in the program formula screens. Also, all pump run times are in seconds.*

## Default Formula

This feature allows the system to be setup so that when the load count pump is operated on any given formula the system will then change to the default formula setting.

1. Use the UP and DOWN button to scroll through the Programming Menu to find Default Formula and press ENTER. The display then should show either "NO DEFAULT FORM" or FORMULA = x.
2. This can be changed by pressing ENTER and adjust to the desired setting of "no default formula" or a default formula.
3. Press ENTER to accept the new setting.

**Operation Mode  
Configuration**  
**Formula Lockout**  
**Program Formula**

**Formula Lockout**  
**Formula 1**  
**Time in Min = 00**

**Units  
Calibration**  
**Formula Lockout**  
**Program Formula**

**Form 1 Level 1**  
**P1 020s P4 020s**  
**P2 020s P5 020s**  
**P3 020s**

**Form 1 Delay**  
**P1 020s P4 020s**  
**P2 020s P5 020s**  
**P3 020s**

**Program Formula**  
**Default Formula**  
**Assign Triggers**  
**Load Count Pump**

**Assign Triggers (only displayed in Formula Select Mode)**

This feature allows any pump to be assigned to any trigger signal input.

1. Use the UP and DOWN to scroll through the Programming Menu to find Assign Triggers. Press ENTER and the Assign Triggers screen will be displayed.
2. Use the UP and DOWN to move the asterisk (\*) to the desired pump. Press ENTER and cursor will flash.
3. Use the UP and DOWN to change the desired trigger signal input number.
4. Press ENTER to save the new setting.
5. Repeat steps 2 – 4 for any additional pumps.
6. Press LEFT to move back to the main Program Menu.

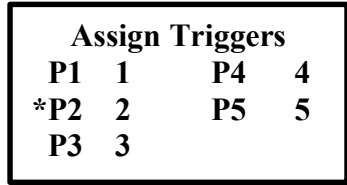
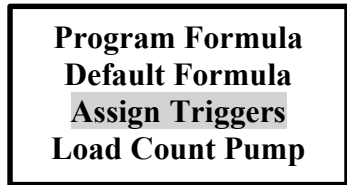

**Enter Sequence –Drain Mode (only displayed in Sequence mode)**

1. Use the UP and DOWN scroll through the Programming Menu to find Enter Sequence and press ENTER. The Sequence screen will be displayed.
2. Use the UP and DOWN to move the asterisk (\*) on the right side next to the Formula number. Press the ENTER to change the formula. A cursor will flash next to the formula number.
3. Use the UP and DOWN to change to the desired formula number. When the desired formula number is displayed, press the ENTER button.
4. Use the DOWN to move the asterisk (\*) from Formula to Sequence. Press the ENTER to change the sequence number. A cursor will flash next to the sequence number.
  - a. Use the UP and DOWN to change to the desired sequence number. When the desired sequence number is displayed, press the ENTER.
  - b. Use the DOWN to move the asterisk (\*) to the row of pump numbers along the bottom edge of display.
  - c. Press the ENTER to program pumps to run at the displayed Sequence number.
  - d. A cursor will flash over the number 1 in the pump row. Use the RIGHT and LEFT buttons to move the cursor and the UP and DOWN to add to run a pump or remove a pump operation that had been previously programmed. When UP is pressed an asterisk (\*) will appear indicating that this pump will run. When DOWN is pressed the asterisk (\*) will be removed, indicating that the pump will not run.

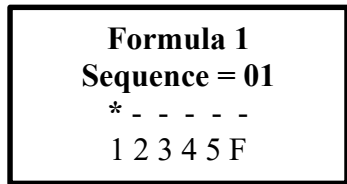
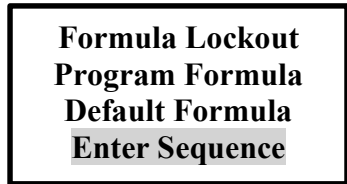

Note: The “F” in the pump row represents the final sequence event (final fill on the laundry machine). Program an asterisk (\*) above the “F” when the final sequence event (final fill on the laundry machine). This will reset the sequence count for a new wash cycle. Pumps can be programmed to run on the final event.

5. Repeat step 4 for all sequence events in the displayed formula.
6. Repeat all steps for additional formulas.

Note: Each formula will require complete sequence mode programming.

**Load Count Pump (not displayed in Relay mode)**

Select a pump for each formula that will be counted each time it is operated (does not count when pump is primed).

1. Scroll through the Programming Menu to find Load Count Pump and press ENTER.
2. Use the UP and DOWN to select the formula. Press ENTER to change the displayed load count pump for the displayed formula. A cursor will flash next to the setting.
3. Use UP and DOWN to select a desired load count pump.
4. Press the ENTER to save the results.
5. Press LEFT to return to the Program Menu.

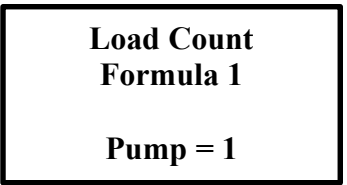
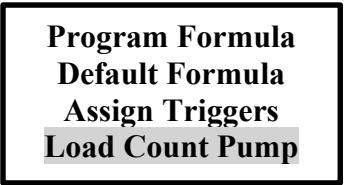

### Trigger Time (only displayed in Formula Select, Flex Trigger or Sequence modes)

Programs a qualification time for triggers received. The trigger time defines how long an uninterrupted trigger signal from the laundry machine is required to start a pump operation. The range is 2 to 90 seconds. The factory default is 5 seconds.

1. Use the UP and DOWN to scroll through the Programming Menu to find Trigger Time and press ENTER. The Trigger Time program menu will be displayed.
2. Press ENTER to modify the trigger time. A cursor will flash next to the trigger time.
3. Use the UP and DOWN to adjust the time.
4. Press the ENTER key to save the displayed trigger time.
5. Press LEFT to return to the Program Menu.

### Test Formulas

Tests the output of the programmed pump by allowing a button to activate the operation in any formula and pump run time. See procedure below:

1. Scroll through the Programming Menu to find Test Formulas and press ENTER.
2. To Select the Formula:
  - a. Use UP and DOWN to move the asterisk to the Formula Setting and press ENTER. A cursor will flash next to the formula number.
  - b. Use UP and DOWN to find the desired formula and press ENTER when the desired formula number is displayed.
3. To Select the pump to be tested;
  - a. Use UP and DOWN to move the asterisk (\*) to the Pump Setting and press ENTER. A cursor will begin to flash on the far right of the Pump Setting.
  - b. Use UP and DOWN button to select a Pump and RT (Level 1 or Level 2 run time). When the desired Pump and RT are displayed press ENTER.
4. To Test the Pump Output or Time;
  - a. Use UP and DOWN to move the asterisk to the Start selection.
  - b. Press ENTER to start the pump and allow the pump to operate an either time or collect the output in a graduated cylinder to check for accuracy.

Note: When the pump is running the “Start” function will become a “Stop” function. The pump can be stopped if necessary.

### Enter Code

Allows a unique passcode to be setup for accessing programming. Passcode is 4 numeric characters.

1. Using the UP and DOWN scroll through the Program Menu and find Enter New Code. Press ENTER and the Enter New Code screen will be displayed.
2. Press ENTER to modify the access code. 4 zeros and a flashing cursor will be displayed.
3. Use the LEFT and RIGHT and UP and DOWN to change the 4 zeros to the desired access code.
4. Press ENTER when the desired access code is displayed. The change will be complete.
5. Press the LEFT to return to the Program Menu.

*Note: If you forget the password, call DEMA Technical Service for directions on how to reset the password.*

### Set Defaults (and Copy Program)

**CAUTION** – Using this feature will erase all programming and restore the dispenser to factory settings.

1. Using the UP and DOWN scroll through the Program Menu and find Set Defaults. Press Enter and the Set Factory Default screen will be displayed.
2. Press ENTER to clear and restore the system to the factory defaults. A screen will appear that has a flashing cursor next to the word “no”.
3. Use the UP or DOWN change to “yes” or back to “no”.

Default Formula  
Assign Triggers  
Load Count Pump  
Trigger Time

Trigger Time  
05s 2-90s

Press Enter

Assign Triggers  
Load Count Pump  
Trigger Time  
Test Formulas

Test Formula  
Formula 1  
Pump = 1 RT 1  
Start

Load Count Pump  
Trigger Time  
Test Formula  
Enter New Code

Enter Code  
Press Enter

Trigger Time  
Test Formula  
Enter New Code  
Set Defaults

Set Factory  
Default

Press Enter

- a. Press ENTER with “yes” displayed to clear the programs and restore the factory defaults. The display will show the system restoring and eventually display “memory cleared”.
  - b. Press ENTER with “no” displayed to move back to previous screen without clearing and restoring factory defaults.
4. Press the LEFT to return to the Program Menu.

**Set Factory  
Default - Yes**

**Copy a program (use Set Defaults)**

Using the Copy Cable (DEMA P/N 84.254.1) programming from another V-Line can be imported to the V-Line.

1. Turn main power off to each V-line using the power switch at the bottom of the V-Line control module.
2. Turn power off to all laundry machines or equipment that the trigger cable of each V-Line may be connected.

**Caution - Before going any further assure that no power is being supplied to the trigger cables to each V-Line.**

3. Remove the 4 screws from the front face of both V-Lines and loosen the front face to access the control board.
4. Using the Copy Cable, connect the cable to the Data Port on each V-Line control board.
5. Turn the main power to each V-Line on using the main power switch at the bottom of the V-Line control module.
6. Enter programming on the V-Line that will receive the programming (not the V-Line that has been programmed).
7. Use the UP and DOWN to scroll through the Program Menu and find Set Defaults. Press ENTER and the Set Factory Defaults screen will be displayed.
8. Press ENTER to clear any programming and import new programming. A screen will appear that has a flashing cursor next to the word “no”.
9. Use the UP or DOWN and change to “yes”.
10. Press ENTER and the display will show the system restoring and eventually display “memory cleared, import program, no”.
11. Press ENTER and a cursor will flash next to the word “no”.
12. Use the UP or DOWN to change to “yes”.
13. Press ENTER and “copying” will be displayed. Eventually this will change to “finished”. At this point the program has successfully been copied to the V-Line.
14. Turn the main power off to the V-Lines.
15. Remove the data cable and reassemble the front face to the V-Lines using the (4) screws.

**Trigger Time  
Test Formula  
Enter New Code  
Set Defaults**

**Set Factory  
Default**

**Press Enter**

**Memory Cleared**

**Import Program  
Yes**

**Memory Cleared**

**Import Program  
Copying**

**Memory Cleared**

**Import Program  
Finished**

**Exit Programming**

Press the ENTER key to return to the Formula screens. Pressing the LEFT arrow from any of the menu screens will display this screen.

**Test Formulas  
Enter New Code  
Set Defaults  
Exit Program**

**Exit Programming**

**Press Enter**

# User Functions and Operation

---

## Changing Formulas at the User Screen

When powered and sitting idle, the V-Line will display the formula, the formula load count and the total load counts for all formulas. Changing Formulas at the Front of the V-Line;

There are three ways to select a formula in all operating modes:

1. The formula may be selected using the UP and DOWN arrows on the dispenser.
2. The V-Line Formula Selector remote may be used to select a formula.
3. Auto Formula Select - see the Auto Formula Select in the Trigger Wiring Section.

## Run a Formula

A formula will be started according to Operating Mode that was set through the programming screens.

- For Push Button mode press the ENTER on the front of V-Line or the START on the Formula Selector Remote and all pumps will start with their delay time followed by their run time.
- For Formula Select mode each pump will respond to its individual trigger.
- For Sequence mode each pump will operate at the input sequence that was programmed.
- For Relay mode each pump will respond to its respective trigger.

When a formula is running the load count will be replaced with a status indicator for each pump. The indicator will show the pump number. The pump number will be above a “D” for delay, an “R” for run, a “-“ for finished, an “H” for hold, or an “L” for locked out. A “-“ indicates that the pump has not yet been triggered. When a flush is used a “+” indicates the flush is running. When the lockout time has expired the display will return to the load counts for the formula.

<p><b>Formula 1</b> <b>Load 0000</b></p> <p><b>Total Loads 0000</b></p>
---

## Prime Pump

1. From the formula select screen press and hold the Left arrow for at least 10 seconds. The Prime Pump screen will be displayed.
2. Use the UP and DOWN to select the desired pump.
3. Press ENTER to start priming.
4. Press ENTER again to stop the pump.
5. To exit the Prime Pump screen, hit the RIGHT arrow and that will take you back to the Formula select screen

<p><b>Prime Pump 1</b> <b>Enter to Stop</b></p>
---

<p><b>Prime Pump 1</b> <b>Enter to Start</b></p>
--

*Note : If the pump is left running it will automatically stop after 2 minutes.*

# Warranty

---

## **Merchandise Returns**

No Merchandise will be returned for credit without DEMA'S written permission. Returned merchandise authorization number is required in advance of return.

## **Product Warranty**

DEMA products are warranted against defective material and workmanship under normal use and service for one year from the date of manufacture. This limited warranty does not apply to any products that have a normal life shorter than one year or failure and damage caused by chemicals, corrosion, physical abuse, or misapplication. Rubber and synthetic rubber parts such as "O"-rings, diaphragms, PVC tubing, and gaskets are considered expendable and are not covered under warranty. This warranty is extended only to the original buyer of DEMA products. If products are altered or repaired without prior approval of DEMA, this warranty is void.

Defective units or parts should be returned to the factory with transportation prepaid. If inspection shows them to be defective, they will be repaired or replaced without charge, F.O.B. factory. DEMA assumes no liability for damages. Return merchandise authorization number must be granted in advance of returned units for repair or replacement (See "Merchandise Returns" above).

# CONTROL MODULE PARTS LIST

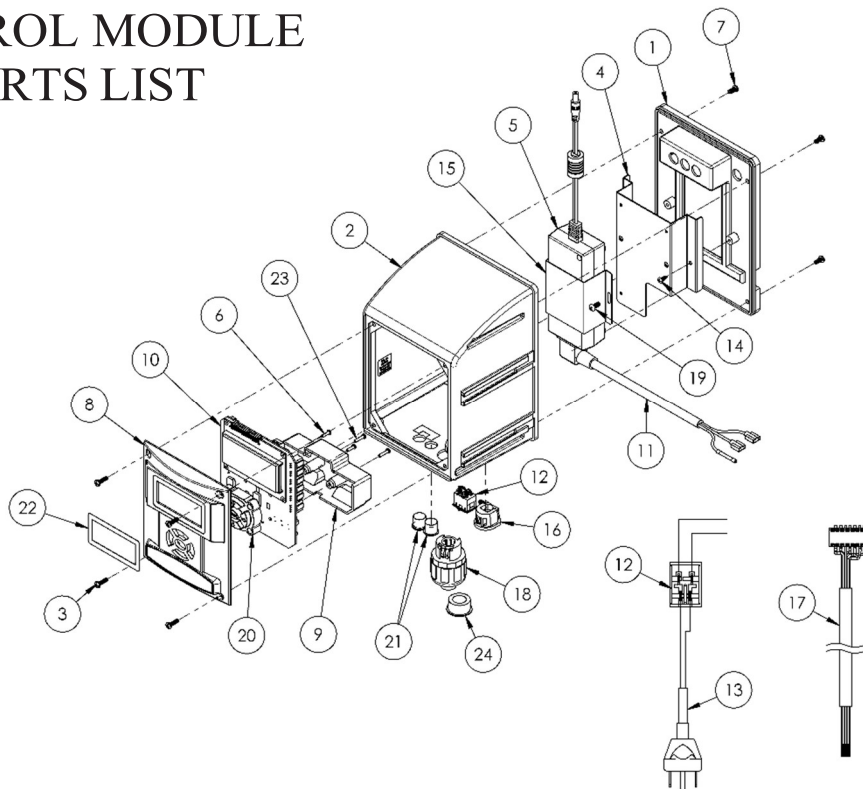

No.	DEMA Part No.	Description
1	84.195.3	Large pump mod enclosure back
2	84.206.3	Large pump mod enclosure assy.
3	41.40.2	#6-32 x 1/2" screw (4 needed)
4	84.5	Base power supply bracket
5	84.65.90	Power supply 2.5A
6	81.20.2	#4 x 3/8" hi-lo screw (6 needed)
7	44.116.2	#8 x 3/8" hi-lo screw (4 needed)
8	84.260.1	Control cover
9	84.261.1	High voltage shield
10	84.250.1	Control board
11	84.125.4	Power supply cable
12	81.163.1	Power switch
13	84.256.1	Cable assy. power cord
14	81.18.1	#6 x 3/8" hi-lo screw (2 needed)
15	84.501	Cover bracket for power supply
16	84.176.3	Strain relief
17	84.252.1	Trigger cable
18	81.148.3	Conduit fitting
19	41.63.2	#8-32 x 3/8" screw (2 needed)
20	81.147.1	Keypad
21	81.47.1	1/2" hole plug
22	L1349	Display label
23	81.20.3	#4 x 1/2" hi-lo screw (2 needed)
24	81.47.4	7/8" hole plug

# PUMP/VALVE MODULE PARTS LIST

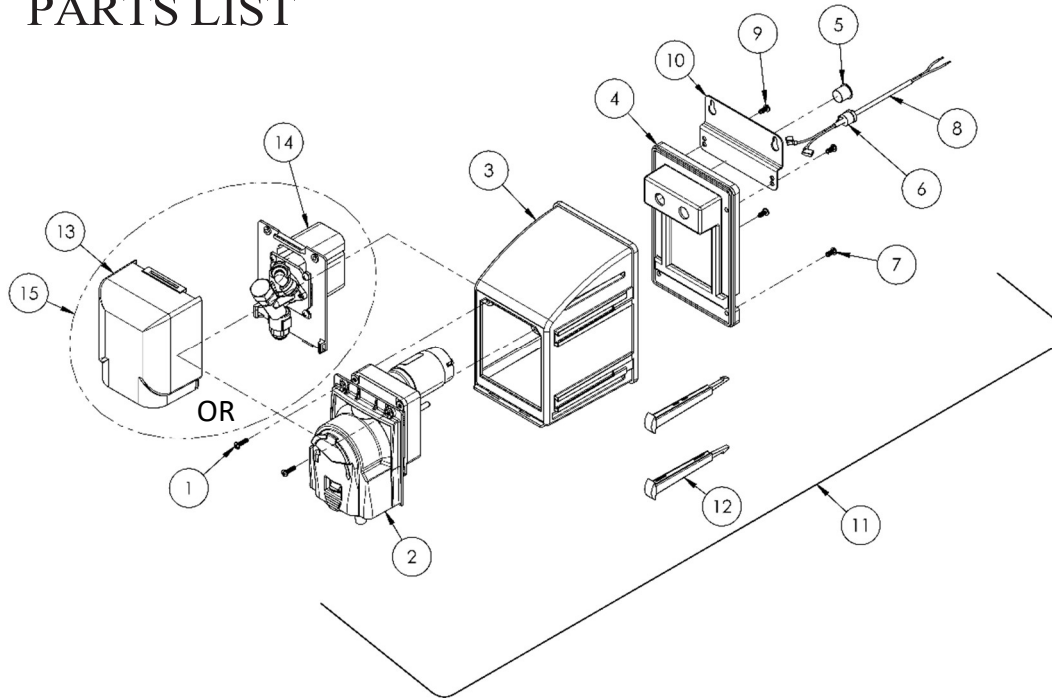

No.	DEMA Part No.	Description
1	41.40.2	#6-32 x 1/2" screw (4 needed)
2*	81.173.9	Pump 2 spring 1/4" id 105rpm, JG, EPDM tubing
	81.173.10	Pump 2 spring 1/4" id 105rpm, barb, EPDM tubing
	81.173.1	Pump 2 spring 1/4" id 60rpm, JG, EPDM tubing
3	81.197.1	Side module enclosure
4	81.143.1	Side module back
5	81.47.1	1/2" hole plug
6	81.183.5	Cable strain relief
7	44.116.2	#8 x 3/8" hi-lo screw (4 needed)
8	81.196.2	Cable assembly
9	44.116.1	#8 x 1/2" hi-lo screw (2 needed)
10	81.324.1	Wall bracket
11	81.198.4	Pump module complete, EPDM tube w/ JG fittings (no wall bracket)
	81.198.6	Pump module complete EPDM tube w/ barb fittings (no wall bracket)
	81.196.14	Pump module complete w/wall bracket, EPDM tube w/ JG fittings
	81.198.15	Pump module complete w/wall bracket, EPDM tube w/ barb fittings
12	81.14 4.1	Side module joint (2 needed)
13	81.14 6.1	Valve cover
14	81.137.7	Valve assembly
15	84.65.32	Valve module complete

\*-There are more options available that have different squeeze tube material. Call for more options.



# LARGE PUMP MODULE PARTS LIST

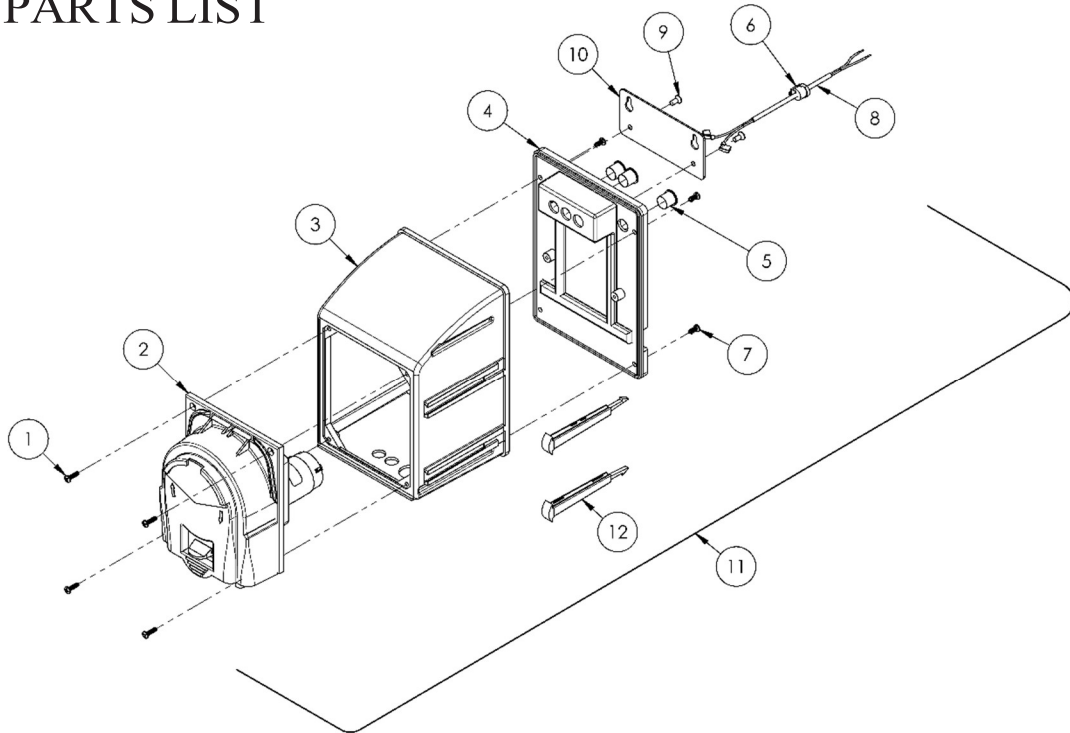

No.	DEMA Part No.	Description
1	41.40.2	#6-32 x 1/2" screw (4 needed)
2*	84.205.1	Pump 2 spring 1/4" id 105rpm, JG, EPDM tubing
	84.205.2	Pump 2 spring 1/4" id 105rpm, barb, EPDM tubing
3	84.206.1	Side module enclosure
4	84.195.3	Side module back
5	81.47.1	1/2" hole plug
6	81.183.5	Cable strain relief
7	44.116.2	#8 x 3/8" hi-lo screw (4 needed)
8	81.196.2	Cable assembly
9	81.19.1	#8 x 3/8" flat head hi-lo screw (2 needed)
10	81.324.1	Wall bracket
11*	84.204.4	Pump module complete, EPDM tube w/ JG fittings (no wall bracket)
	84.204.5	Pump module complete EPDM tube w/ barb fittings (no wall bracket)
	84.204.14	Pump module complete w/wall bracket, EPDM tube w/ JG fittings
	84.204.15	Pump module complete w/wall bracket, EPDM tube w/ barb fittings
12	81.144.1	Side module joint (2 needed)

\* - There are more options available that have different squeeze tube material. Call for more options.